



*Goodwin*

**150 mm DWHH** 150kW 50Hz  
**DIRTY WATER HIGH HEAD  
SUBMERSIBLE PUMP**

**NUMBER ONE FOR RELIABILITY, STRENGTH & ENDURANCE**



**TECHNICAL DATA SHEET**





# 150 mm DWHH

## 150kW 50Hz

### SUBMERSIBLE PUMP

Goodwin submersible pumps have been manufactured since 1982 and are recognised as market leaders in terms of performance and reliability. The pumps have been continually developed over 4 decades resulting in machines that can perform in the most demanding environments.

### Standard Engineering Features

- Single piece cast iron motor housing to enhance rigidity and reduce wear
- 3 phase electric motor runs in oil bath to lubricate and cool the motor parts
- Cooling assisted by the pumped fluid passing through the pump body
- Twin volute casing design to reduce rotational imbalance and increase lifetime of bearings and seals
- Carefully chosen wear resistant materials to maximise service lifetime
- Multiple stage, closed vane impellers
- Precision bearings
- Non pressurised mechanical seal

### Applications

- High wall pumping (open pit) applications
- Construction of buildings, dams & harbour walls
- Long distance pumping applications (up to 4 km)
- Agriculture - irrigation water
- Mine dewatering
- Flood level control - industrial, municipal, mining & marine
- Emergency and environmental control

### Pump Performance

Design fluid handled	Dirty Water
Maximum fluid SG	1.1 kg/l
Maximum fluid solids content	10 % by weight
Maximum particle size	10 mm
Maximum fluid temperature	90 °C
Recommended pH range	4-10
Power	150 kW
Speed	1450 rpm
Weight	2570 kg
Outlet Diameter	150 mm
Maximum Flow	195 m <sup>3</sup> /hr
Maximum Head	190 m (18.6 bar)
Impeller diameter	485 mm
Impeller tip speed	37 m/s
Peak efficiency	47 %
Maximum submergence depth*	28 m
Shut off head at maximum pump speed	190 m

\* as standard, can be deeper if required

### Electrical Data

Motor Type	Squirrel-cage induction motor
Frequency	50Hz
Phase	3
Motor rating	IEC 60034-1
IP protection rating	IP68
Starting method	Direct on-line, Soft Start, Variable Speed Drive. Note: Star Delta not available
Number of starts per hour	10
Voltage variation	± 6%
Voltage imbalance between phases	Max 2%
Insulation Code	H (180°C)
Motor Overload Factor	1.76
Duty Rating	S1
Efficiency Class	IE exempt (integral with pump)
Oil Type	Mineral uninhibited to IEC 60269 (04)
Standards complied with	IEEE 112-2004, IEC 60034-1-2, AS60034-1, JEC 37
Noise level at 1m when not submerged	78 dB
Motor efficiency	88%





# Goodwin



## Electrical Data

Voltage	Rated power (kW)	RPM	Rated (full load) Current (A)	Inrush Current Soft Start (A)	No Load Current (A)	Power Factor cos φ (full load)	Power Factor cos φ (75% load)	Power Factor cos φ (50% load)	Recommended Over Current Protection (A)
380	150	1450	284	994	58	0.91	0.82	0.81	500
415	150	1450	261	914	56	0.91	0.82	0.81	400
525	150	1450	204	714	45	0.91	0.82	0.81	350
660	150	1450	162	567	36	0.91	0.82	0.81	350
1000	150	1450	106	371	28	0.91	0.82	0.81	300

## Materials

Pump body castings	SG Iron
Impeller	Hardened stainless steel
Casing	SG Iron
Wear plate	SG Iron
Shaft	Martensitic stainless steel
Mechanical seal	Stainless steel and silicon carbide
O-rings	Nitrile rubber
Fasteners	Stainless steel

## Coating System

Surface preparation	Class 2.5
Undercoat	Two component high build epoxy coating. 125µm thickness (typical).
Top coat	Acrylic polyurethane high gloss. 50µm thickness (typical). Yellow to RAL 1003 / BS4800 08-E-51.

## Other Data

Recommended cable	Heavy duty 95mm <sup>2</sup> 3 phase + earth copper cored cable with black chlorinated polyethylene (CPE) rubber sheathing. To standard EN 50525-2-21. Voltage rating 750V. Outer sheath is oil resistant to IEC 60811-404, flame resistant to IEC 60332-1-2. Maximum external diameter 52.3mm. Weight 5.5kg/m.		
Recommended lifting chains	Length: 0.6 m	Material: Steel	SWL: 3200 kg
Hose connection	Outlet flange configuration	150mm PN25 M24*3.0P 8 places Ø250mm PCD	
Cable gland	Material	Nickel plated brass (stainless steel optional)	
	Specification	BS6121:Part 1:1989	
Control panel	Rating	IP65	
	Weight	108kg	
	Description	Voltage protection, earth leakage protection, phase imbalance, automatic operation with level switch and timer. Soft start as standard (VSD optional).	



**150 mm DWHH** 150kW 50Hz  
**SUBMERSIBLE PUMP**

**Weights & Dimensions**

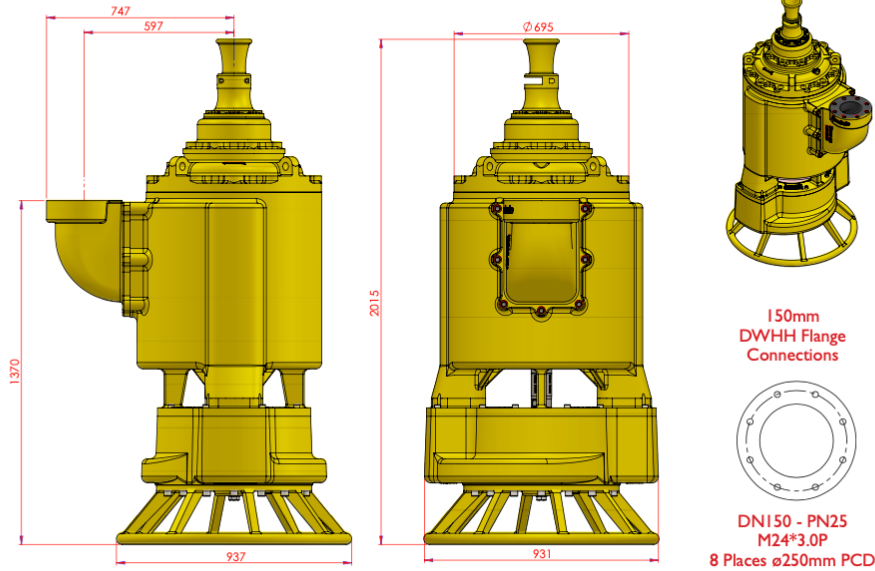

**Pump Curve**

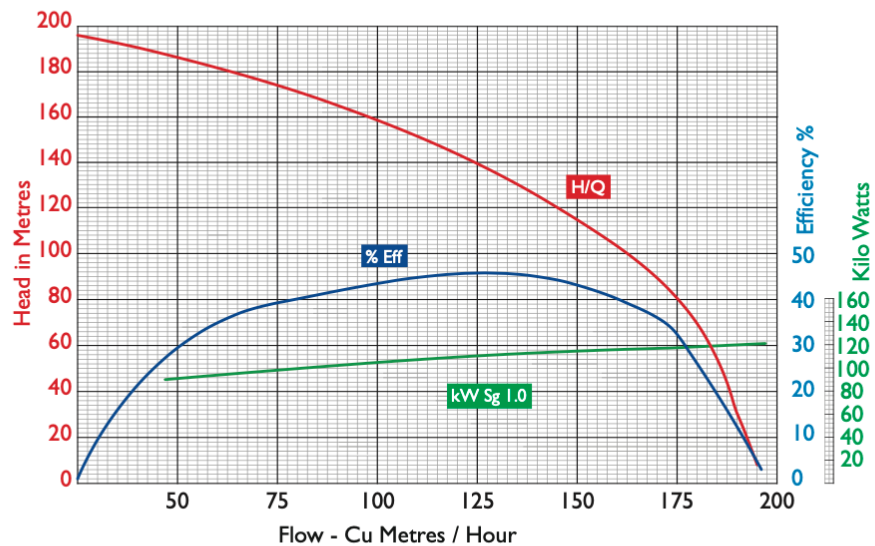

All pump designs and information is subject to upgrade and revision.

Doc.Ref 150 DWHH 50 ENG.VI 10.2020

**Goodwin**